



Journal Home Page

<https://www.ijseam.com/volume-1/>

INTERNATIONAL JOURNAL
OF SCIENCE, ENGINEERING,
ARTS & MANAGEMENT

An Automatic Smart Plant Watering System

Dr. Y. L. Ajay Kumar

Professor of ECE Department, Anantha Lakshmi
Institute of Technology and Sciences, Anantapur,
Andhra Pradesh, India

P. Chandana

Assistant Professor of ECE Department, Anantha
Lakshmi Institute of Technology and Sciences,
Anantapur, Andhra Pradesh, India

K. Shireesha Gangothri

UG Students of ECE Department, Anantha Lakshmi
Institute of Technology and Sciences, Anantapur,
Andhra Pradesh, India

S. Sravani

UG Students of ECE Department, Anantha Lakshmi
Institute of Technology and Sciences, Anantapur,
Andhra Pradesh, India

P. Bhavana

UG Students of ECE Department, Anantha Lakshmi
Institute of Technology and Sciences, Anantapur,
Andhra Pradesh, India

Y. Nirosha

UG Students of ECE Department, Anantha Lakshmi
Institute of Technology and Sciences, Anantapur,
Andhra Pradesh, India.

G. Sruthi

UG Students of ECE Department,
Anantha Lakshmi Institute of Technology and Sciences, Anantapur,
Andhra Pradesh, India

Please cite this article in press as Shaziya Mohammed Irfan Momin et.al. Role of Entrepreneurship in Sustainable Chemistry. International Journal of Science, Engineering, Arts & Management.2024:2(1)

Copy right © 2024 This is an Open Access article distributed under the terms of the International Journal of Science, Engineering, Arts & Management, which permits unrestricted use, distribution, and reproduction in any medium, provided the original work is properly cited

ARTICLE INFO	ABSTRACT
<p>Article history</p>	<p>Smart plant watering solutions utilize sensors, automation, and IoT technologies to optimize irrigation by monitoring soil moisture, temperature, and environmental conditions. These systems automate watering schedules, ensuring plants receive the right amount of water, reducing waste, and promoting efficient water use. By integrating real-time data and weather forecasts, they offer a sustainable approach to plant care for both home gardens and agricultural applications, contributing to water conservation and improved plant health.</p>
<p>Keywords</p> <p>Smart irrigation, plant care automation, soil moisture sensors, IoT in agriculture, water conservation, automated watering system, precision irrigation, environmental monitoring, sustainable gardening, smart gardening solutions</p>	

Introduction

Water is a vital resource for plant growth, and ensuring plants receive the right amount of water is crucial for their health and development. Traditionally, plant watering has been a manual task, often leading to either overwatering or under watering, both of which can negatively affect plant health and waste resources. In recent years, smart plant watering solutions have emerged as a response to these challenges, leveraging advancements in technology to automate and optimize the irrigation process. Smart watering systems combine sensors, IoT (Internet of Things) devices, and automation technologies to monitor environmental factors such as soil moisture, temperature, and humidity in real-time. These systems use this data to automatically adjust the watering schedule, ensuring plants receive optimal hydration without human intervention. In some cases, they also integrate weather forecasts to further refine irrigation decisions, avoiding unnecessary watering during rainy conditions. The development of smart plant watering solutions aligns with growing concerns over water conservation, particularly in regions facing water scarcity. By reducing water waste and ensuring efficient plant hydration, these systems offer a sustainable solution for both home gardeners and large-scale agricultural operations. As we explore the potential of smart watering systems, it becomes clear that they not only simplify plant care but also contribute to broader environmental conservation efforts.

Methods:

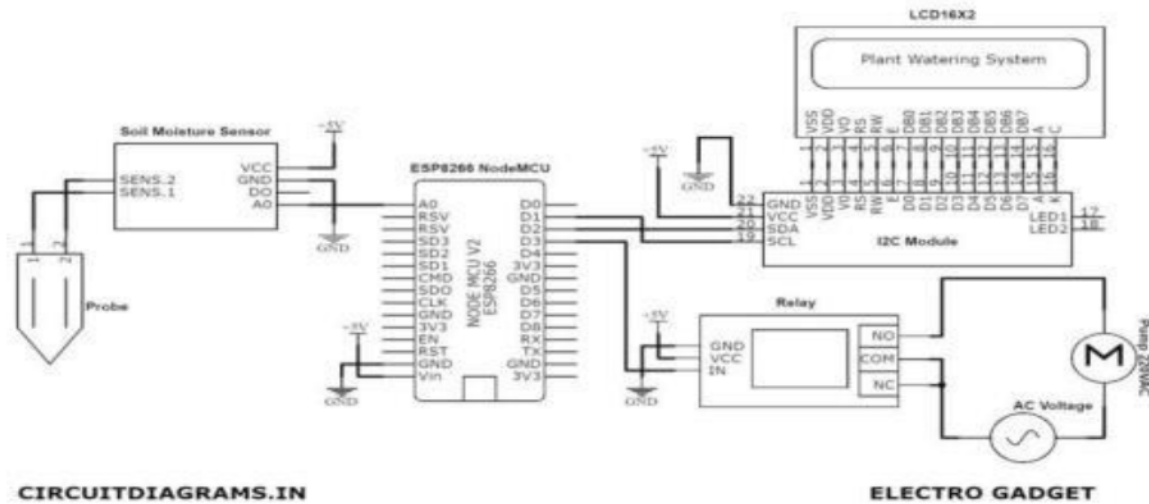

Fig 1: Circuit Diagram of smart plant watering system

1. Components Used:

Mini DC motors : A small motor is one kind of electric motor, and the main function of this is to change the Energy from electrical to mechanical. Small motors are used in electric watches. Dc - motor.

L298N motor driver module : The L298N is a dual H-Bridge motor driver which allows Speed and direction control of two DC motors at the same time. The module can drive DC motors That have voltages between 5 and 35V, with a peak current up to 2A.

Soil moisture sensor: Soil moisture sensors measure or estimate the amount of water in the soil. These sensors Can be stationary or portables such as handheld probes.

HW battery: These Hi - Watt 9V Battery is the most commonly used and portable 9V battery. It is non - Rechargeable and is a high capacity and low - cost solution for many electronic devices

Jumper wires: It A jumper wire is also known as jumper, jumper wire, DuPont wire) is an Electrical wire, or group of them in a cable, with a connector or pin at each end (or sometimes Without them - simply "tinned"), which is normally used to interconnect the components of a Breadboard or other prototype or test circuit.

2. Experimental Setup:

System Assembly:

In an experimental setup for a smart plant watering system without using an Arduino, the core components include an L298N motor driver, a soil moisture sensor, a mini DC motor, a 9V HW battery, and jumper wires. The system functions autonomously based on the moisture levels in the soil, detected by the soil moisture sensor.

The soil moisture sensor detects the moisture content in the soil and outputs a signal. The sensor typically has a digital output (D0) that can be used to directly trigger the motor without a microcontroller. When the soil is dry, the sensor's digital output sends a HIGH signal, which can be used to activate the L298N motor driver.

The L298N motor driver controls mini DC motor, which is connected to a small water pump. When the sensor signals that the soil is dry, the motor driver receives the signal and powers the motor, enabling the

pump to deliver water to the plant. Once the moisture level increases and the sensor detects wet soil, the signal turns LOW, cutting power to the motor, and stopping the water flow.

The 9V HW battery provides power to the motor driver and the DC motor. The motor driver's input terminals are connected to the sensor output, and the motor driver's output terminals are connected to the mini motor. Jumper wires are used to establish connections between the battery, motor driver, moisture sensor, and DC motor. The absence of a microcontroller simplifies the design, relying on the soil moisture sensor's direct output to control the watering process.



Fig 2: Experimental Setup

Result:

The Smart plant watering solutions efficiently water plants by automatically adjusting based on soil moisture levels, which helps in conserving water and reducing waste. This automation saves time and effort, ensuring plants receive consistent and appropriate moisture for healthier growth. Additionally, some systems offer remote monitoring and control, allowing users to manage their plants from anywhere.

Discussion

Smart plant watering solutions represent a significant advancement in horticultural technology, offering a sophisticated approach to plant care. By integrating soil moisture sensors with automated watering systems, these solutions ensure that plants receive precise amounts of water based on their current needs. This targeted watering approach not only conserves water but also minimizes the risk of overwatering or under watering, which can lead to healthier plants and improved growth outcomes. Moreover, the convenience of automation reduces the time and effort required for plant care, making it particularly beneficial for busy individuals or those managing multiple plants. Many advanced systems also feature remote monitoring capabilities, allowing users to track soil moisture levels and control watering schedules from anywhere, thus adding an extra layer of flexibility and control. Overall, smart plant watering solutions enhance plant health, promote resource efficiency, and offer significant convenience, making them a valuable investment for both casual gardeners and horticulture enthusiasts.

Conclusion

In conclusion, the smart plant watering solution offers an efficient, automated approach to maintaining optimal soil moisture levels without the need for constant human intervention. By leveraging simple

components like the L298N motor driver, a soil moisture sensor, a mini DC motor, and a power source, the system ensures that plants receive water only when necessary. This not only conserves water but also promotes healthier plant growth by preventing over or under-watering. The setup is versatile and scalable, making it an ideal solution for both small-scale home gardening and larger agricultural applications. Its simplicity, affordability, and reliability make it a practical and effective tool for modern, sustainable plant care.

References

- Home Automation Systems - A Study. April (2015)International Journal of Computer Applications.
https://www.researchgate.net/publication/275338025_Home_Automation_Systems_-_A_Study
- Sound-Based Control System Used in Home Automation January 2018Lecture Notes in Electrical Engineering .In book: Computational Signal Processing and Analysis (pp.267- 278). [https://www.researchgate.net/publication/324159705_Sound- Based_Control_System_Used_in_Home_Automation](https://www.researchgate.net/publication/324159705_Sound-Based_Control_System_Used_in_Home_Automation)
- Home Automation Control System by IRJET journal https://www.academia.edu/89843466/Home_Automation_Control_System
- Secure and Smart Home Automation System with Speech Recognition By Chandra Irugalbandara 1,2,Abdul Salam Naseem 1,Sasmitha Perera 1,Sithamparanathan Kiruthikan 1 andVelmanickam Logeeshan 1,*ORCID <https://www.mdpi.com/1424->